

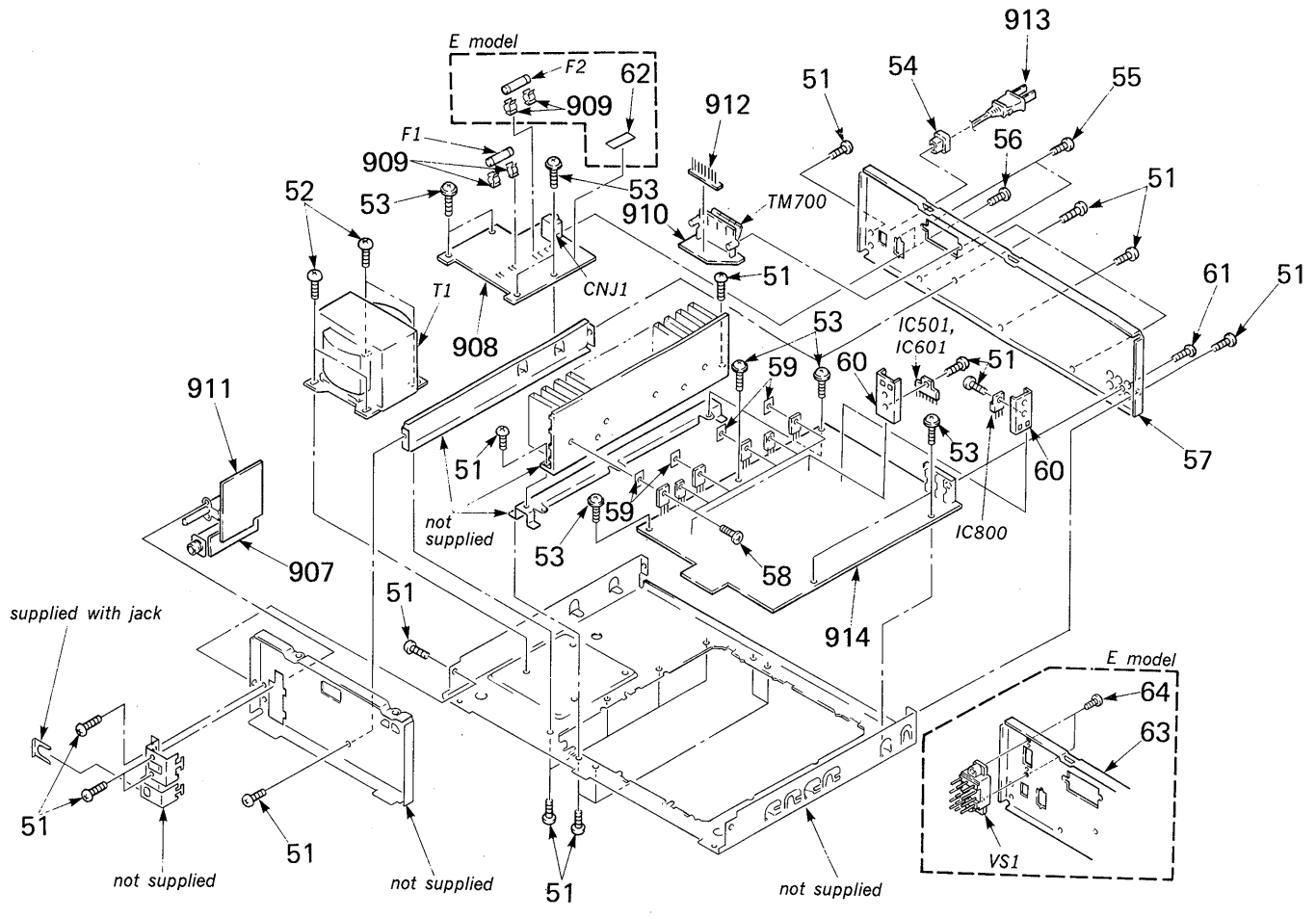





**SEE ADDITIONAL  
INFORMATION**

**5-2. CHASSIS SECTION**



<p><b>Note:</b> The components identified by mark  or dotted line with mark  are critical for safety. Replace only with part number specified.</p>	<p><b>Note:</b> Les composants identifiés par une marque  sont critiques pour la sécurité. Ne les remplacer que par une pièce portant le numéro spécifié.</p>
--	--