

8-1-2. CHASSIS SECTION (GX310)

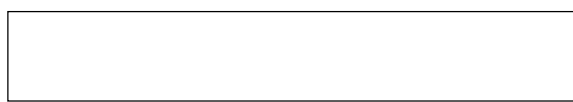

8-1-3. OVERALL SECTION (HX710/HX910)

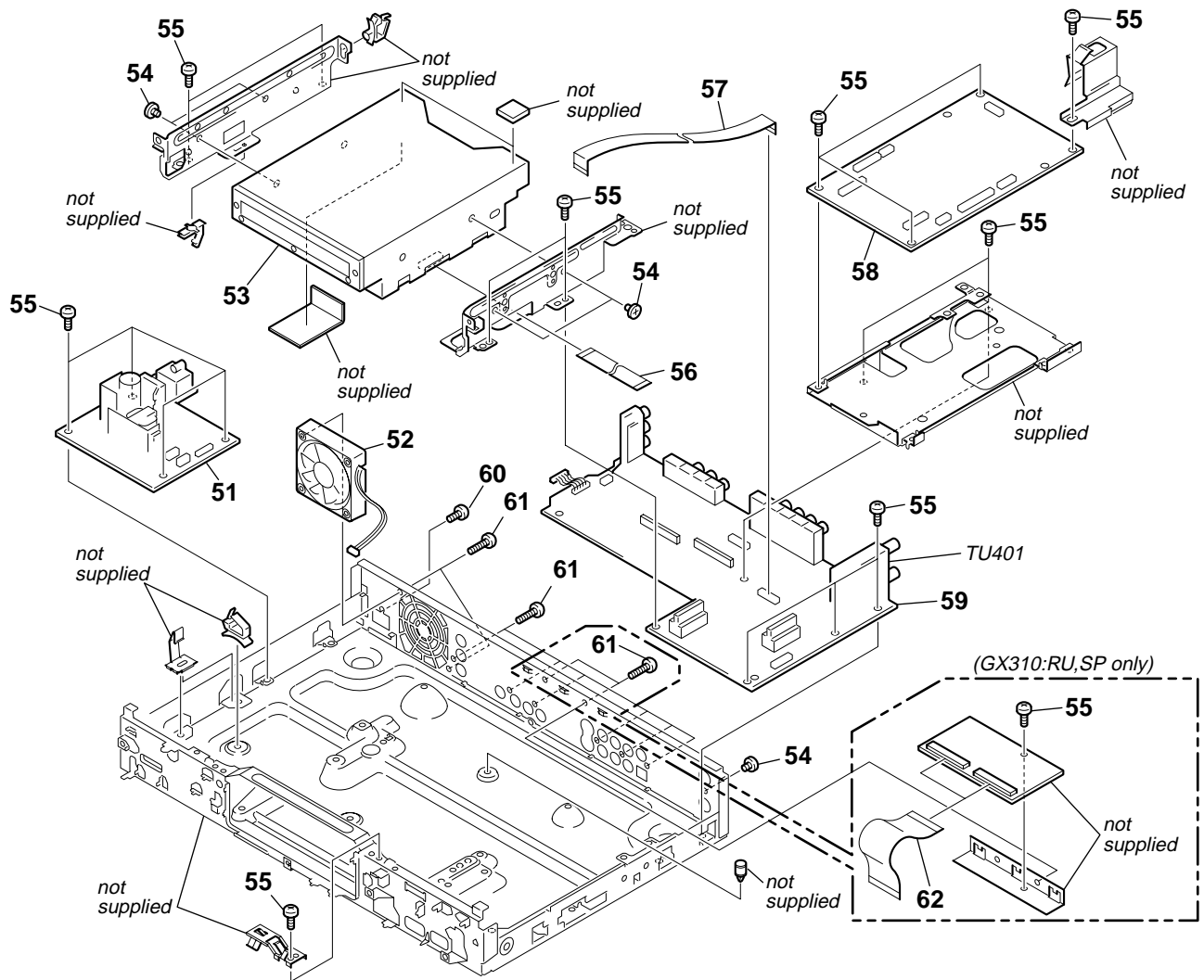
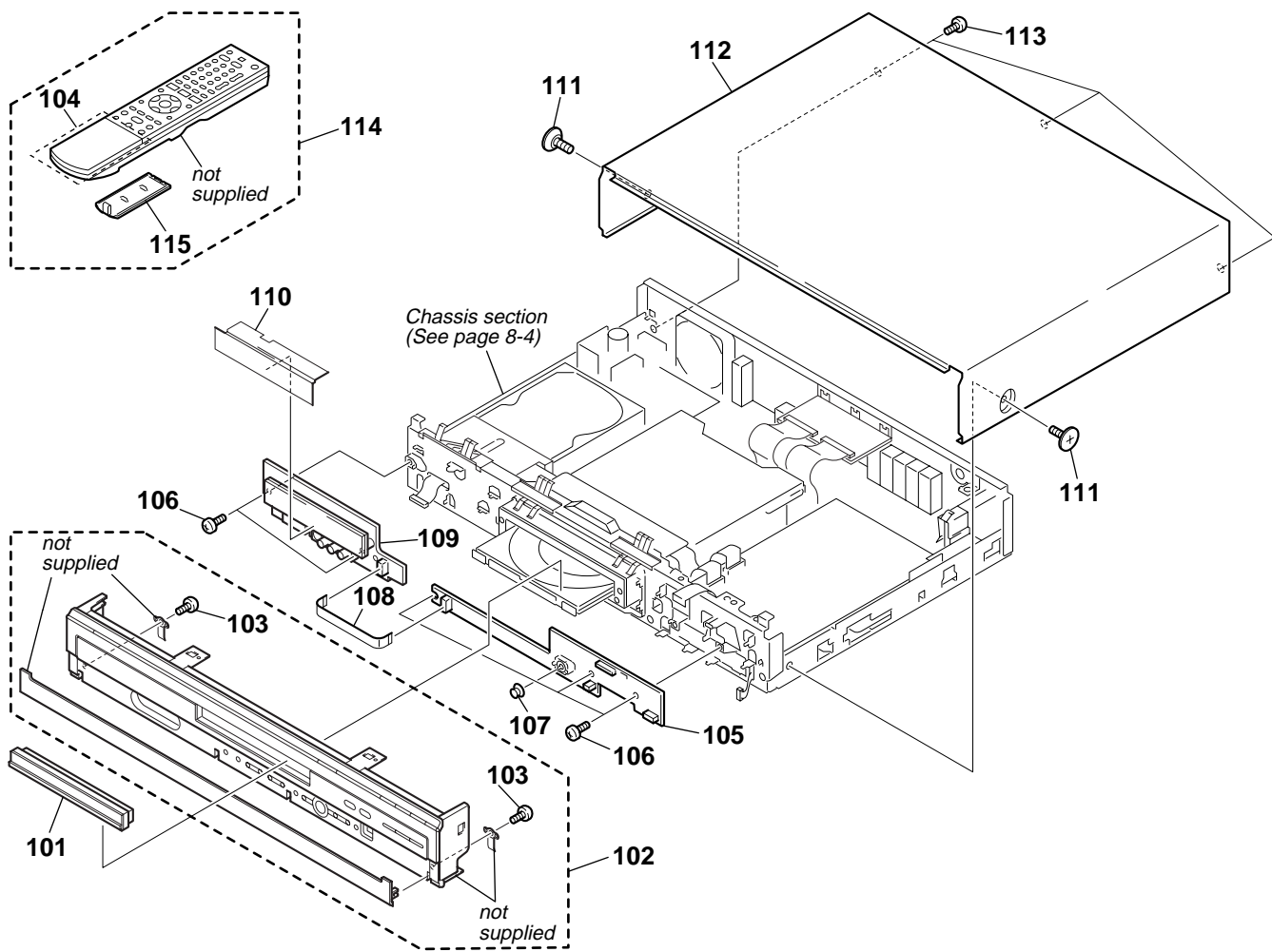

8-1-4. CHASSIS SECTION (HX710/HX910)

